

# VALIDATION OF WELDING STRUCTURE SIMULATIONS

T. LOOSE\*, T. GIRRESSER\*\* and J. GOLDAK\*\*\*

*\*Dr. Loose GmbH, 75045 Walzbachtal, Germany, Orcid Id: 0000-0002-1756-0392, [loose@dr-loose-gmbh.de](mailto:loose@dr-loose-gmbh.de)*

*\*\*Technologie-Institut für Metall & Engineering GmbH (TIME), 57537 Wissen / Steg, Germany, [tobias.girresser@time-rlp.de](mailto:tobias.girresser@time-rlp.de)*

*\*\*\* Goldak Technologies Inc., KIV 7C2 Ottawa, Canada, [john.goldak@goldaktec.com](mailto:john.goldak@goldaktec.com)*

## ABSTRACT

The Welding structure simulation is a numerical method that predicts distortions, residual stresses and microstructure in welded structures. It enables design engineers to optimize the design and the manufacturing process for the strength and usability of the assembly. To trust the simulation software, it should be validated to demonstrate that the predictions provide a best fit with the reality.

We want to prove, that our numerical model of simulation matches the physical behavior of the reality. We must ensure that the virtual experiment matches the physical experiment and that we compare the same sensor and virtual data:

- Same time
- Same location
- Same state

Previously, the comparison between the virtual and physical experiment was limited to the final result: final distortion, final residual stress and final residual strain. Now also the transient state during the process shall be considered: transient measurement of temperature field, strain field or deformation.

This validates not only the final results but also the computational algorithm that leads to these results.

This paper presents transient results of validation experiments with the scope on deformation. The experiment, welding of an orthotropic plate, was chosen in accordance with a published experiment from Murakawa [1]. Because the process is transient, it is important that the transient data be compared.

## INTRODUCTION

The weld structure simulation as a special application of the finite element method considers the effects from welding on the entire component. The input variable is the heat input from the welding heat source. This is applied in the form of a so-called equivalent heat source. This means that any fusion welding process can be modelled, regardless of how the fusion heat is generated. Of course, all boundary conditions must be considered in the model. This includes the clamping device, heat dissipation through clamping or cooling jaws and tacking.

Results from the weld structure simulation include the geometry change due to welding, weld distortion, residual stresses and plastic strains, and if the microstructure transformation

calculation is included, the microstructure state after welding and the resulting changing yield strength.

The most precise method is the transient method. The transient method provides results over time and is chosen as the simulation method for the virtual experiment.

Since the transient method involves a large computational overhead in terms of time, simplifying methods have been developed in the past. These include the metatransient method [2] or the shrinkage force method. In the metatransient method, a seam section is heated simultaneously instead of a migrating heat source. In the shrinkage force method, substitute expansions are applied in the seam area. Both methods are intended to provide accurate final results, but the results over time may differ from reality.

The specimen for the Experiment is shown in figure 1.



**Fig. 1** Test specimen - TIME stiffened plate

## EXPERIMENTAL SETUP

For this purpose, an orthotropic plate 1200 mm x 600 mm x 6 mm made of low alloyed steel grade S235JR was chosen. On the plate, two longitudinal stiffeners 1000 mm x 100 mm x 6 mm and 3 transverse stiffeners 400 mm x 100 mm x 6 mm were welded. The stiffeners are fixed with a total of 17 tack welds (fig. 2).

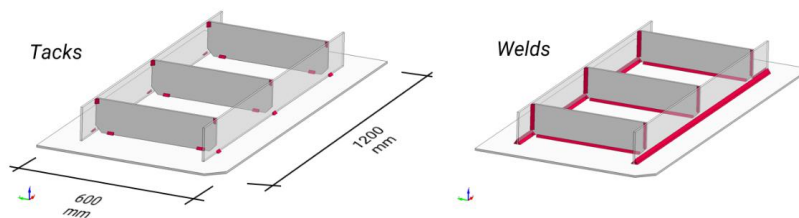
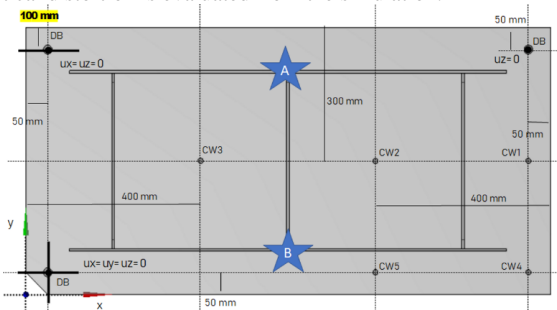

**Fig. 2** Dimension, tack welds and welds of test specimen

The slab is supported in a statically determinate manner and supported at three corners. The fourth corner remains free. This is the corner where the greatest distortion occurs during welding. The corner opposite the free corner on the long side is chamfered so that the corners of the plate can be clearly assigned (fig. 3). While the tack welds are being welded, the plate is supported at the center transverse stiffener on each outer side with a jack (fig 3, “A” and “B”). Without support, the plate deflects under its own weight to such an extent that an excessive gap is created between the plate and the stiffener. After tack welding, the support is removed. This leads to a lowering of the plate at the unsupported corner. In the simulation, the removal of the support is mapped realistically.

Since only rigid body modes are constrained by the permanent supports, the experimental setup allows significant deformation during welding. This is intended to provide a meaningful comparison between the calculated and the experimental results.

During welding, the movements normal to the plate are measured at five points with cable wire sensors. The position of the cable wire sensors is shown in fig. 3 too. At the same locations, the vertical distortion is evaluated from the simulation.



**Fig. 3** The points with permanent support that constrain rigid body motion are labelled DB, the temporary supports are labelled A and B and the wire sensors are labelled CW1 to CW5

The weld sequence is documented in fig. 4. The longitudinal seams are first welded on the outside as a two-layer seam with 3 weld beads. All other 17 seams are executed as single-layer fillet welds.

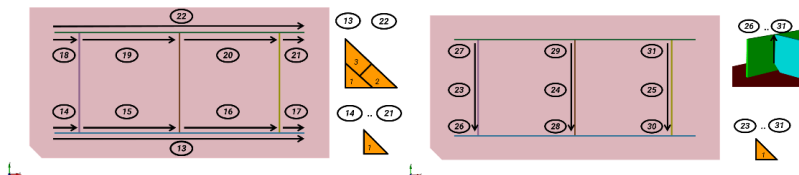

**Fig. 4** Weld sequence

There are two groups of welds, fillet weld in horizontal position PB and vertical fillet weld in ascending position PG.

Process parameter for the horizontal welds, position PB:

- Wire Diameter: 1,2 mm
- Wire feed speed: 8 m/min
- Travel speed: 45 cm/min
- U:  $23.5 \pm 2$  V, I:  $258 \pm 10$  A
- Weave bead with
  - amplitude: 1 mm
  - frequency: 2.78 Hz

Process parameter for the vertical welds, position PF:

- Wire Diameter: 1,2 mm
- Wire feed speed: 2 m/min
- Vertical travel speed: 4.9 cm/min
- U: 14.9 V, I: 96 A
- Triangle weave bead with
  - Weave speed: 50 cm/min
  - Weave amplitude: 5.5 mm
  - Weave frequency: 2 Hz

#### DATA SYNCHRONISATION

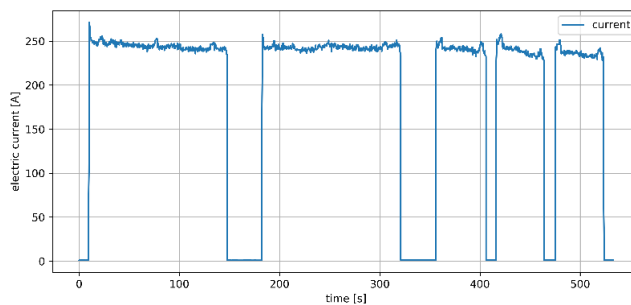

**Fig. 5** Electrical current during welding

The challenge is to synchronize the measured data from experiment with the simulated data. For this purpose, the welding times are recorded redundantly several times:

- Time determination with stopwatch and manual logging
- Video recording
- Recording with infrared camera (FLIR)
- Measurement of current (fig. 5) and voltage during welding
- Recording with infrared camera (FLIR)
- Measurement of current and voltage

From the redundant recording, the start and end times of the individual welding beads can be determined very precisely and entered them into the process plan for the simulation.

### NUMERICAL MODEL AND SIMULATION

The plate is represented by solid element model with hexahedron and pentahedron elements. The general mesh size is 5 mm, the mesh size in filler area 1 mm lateral. 2 element layers are chosen in plate thickness direction (fig. 6). The single parts are meshed independently with non-coincident mesh and joined to each other by contact formulation.

$$q_i = Q f_i \frac{3}{2\pi a_i b c} \quad \text{with } i := \{f, r\} \quad (1) q = \frac{3FQ}{2\pi abc}$$

$$q = q_f \quad \text{if } u \geq 0 \quad \text{and} \quad 1 > \left(\frac{u}{a_f}\right)^2 + \left(\frac{v}{b}\right)^2 + \left(\frac{w}{c}\right)^2 \quad \text{else} \quad (2)$$

$$q = q_r \quad \text{if } u < 0 \quad \text{and} \quad 1 > \left(\frac{u}{a_r}\right)^2 + \left(\frac{v}{b}\right)^2 + \left(\frac{w}{c}\right)^2 \quad \text{else} \quad q = 0 \quad (3)$$

The double-ellipsoidal heat source is used. In contrast to Goldak's assumption [3], a constant distributed heat source density is assumed over the ellipsoid [2] according to Eqn. (1) to (3). In Eqn. (1) to (3)  $q$  denotes the energy density per unit time,  $Q$  denotes the energy per unit time,  $a$ ,  $b$  and  $c$  denote the radii of the ellipsoid and  $u$ ,  $v$ ,  $w$  denote the local heat source coordinates, with respect to indices  $f$  as front and  $r$  as rear. A single-phase material model is applied which considers the transformation strain and temperature dependent material parameters. For the mechanical material part, LS-DYNA material model \*MAT 270 is used and \*MAT T07 for the thermal material model, respectively.

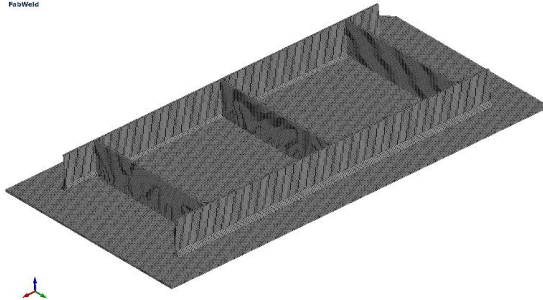

**Fig. 6** Simulation - model mesh

FabWeld is used for the model setup and the LS-DYNA code for the calculation. In [Fig.7](#) the calculated temperature field on 5-times magnified deformed structure is displayed.

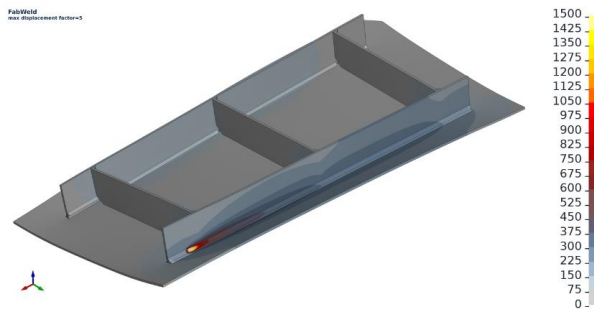

**Fig. 7** Temperature displayed on 5-times magnified deformed structure

## RESULTS

Fig. 8 to Fig. 12 show the result of the validation test for the five cable wire sensors. The graph compares the vertical deformations measured with cable wire transducers with the calculated vertical deformations. It can be seen on the graph that the deformation jump caused by removing the center bearings after tack welding is accurately represented by the simulation. The vertical distortion during the entire welding process is also calculated correctly. This proves that the applied calculation method of the weld structure simulation can accurately reproduce the deformation behavior during the entire welding process. This finding is new, since previously only final results, i.e., the condition after welding and cooling, were used for validation. In order to fully use weld structure simulation to analyze welding, the simulation results must also be accurate throughout the process. For example, this comes into play when the gap formations during welding are to be investigated to check the clamping or tacking concept.

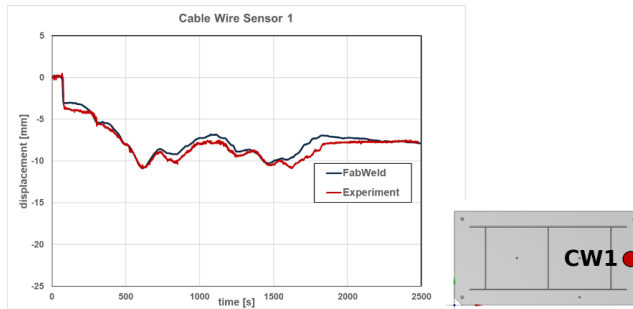

Fig. 8 Result cable wire sensor 1

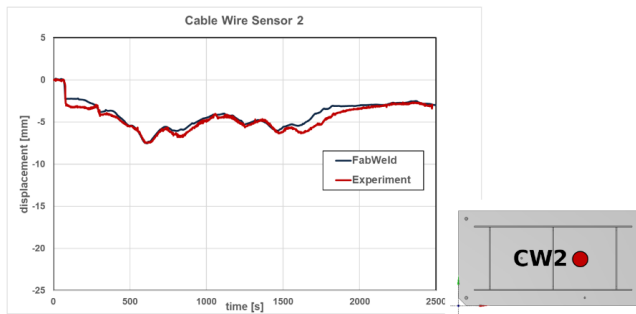

Fig. 9 Result cable wire sensor 2

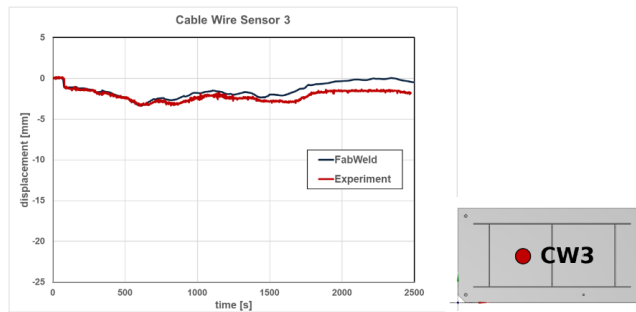

Fig. 10 Result cable wire sensor 3

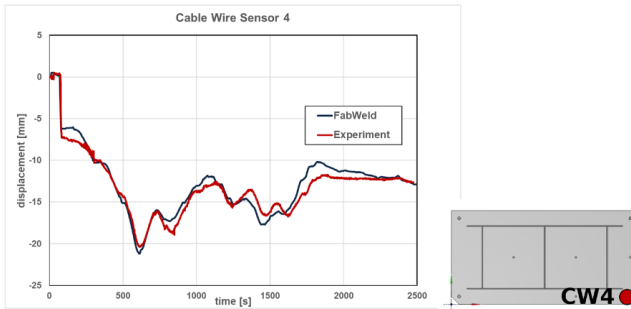

Fig. 11 Result cable wire sensor 4

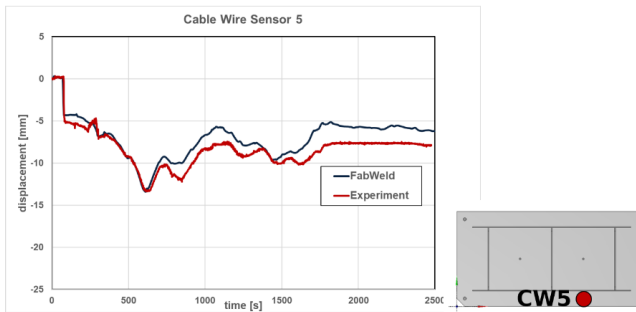

Fig. 12 Result cable wire sensor 5

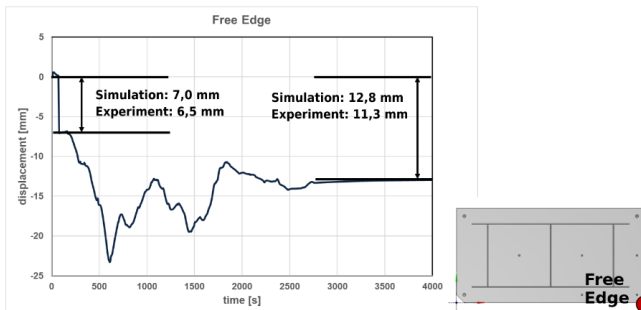
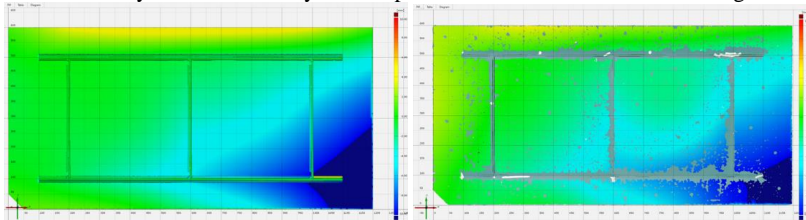

Fig. 13 Vertical deformation on free edge

Fig. 13 shows the vertical deformation on the free edge. The calculation results are confirmed by discrete measured values from the physical experiment. Firstly, the vertical jump when removing the temporary jacks after tack welding, and secondly by the total distortion



after complete cooling. In addition, the warped structure after complete cooling is also calculated correctly. This is shown by the comparison of the surface deviation in Fig. 14.



**Fig. 14** Surface deviation. Left simulation, right experiment

## SUMMARY AND CONCLUSION

An orthotropic plate made of low alloyed steel grade S235JR with gas metal arc fillet welds is chosen for validation experiment to demonstrate the calculation quality of the welding structure simulation. The model is set up according to the state of the art.

It could be shown, if one

- predicts the material behavior correctly,
  - predicts the driving physical effects,
  - predicts the right boundary conditions,
  - predicts the process correctly,
  - compares synchronized data - same location - same time,
- one obtains agreement between virtual simulation and real experiment.

This study shows that weld structure simulation can be used for accurate distortion prediction. This makes it possible to understand the distortion behavior and to perform efficient distortion management.

## REFERENCES

- [1] [WANG, J., SHIBAHARA, M., ZHANG, X., MURAKAWA, H.: 'Analysis of Twisting Distortion of Thin Plate Stiffened Structure Caused by Welding'. \*Journal of Materials Processing Tech.\*, 2012 Vol. 212, Issue 8, pp 1075-1715.](#)
- [2] T. LOOSE and J. ROHBRECHT: 'Equivalent energy method for welding structure analysis', *Welding and Cutting*, Vol. 17, No. 3, 2018.
- [3] J. GOLDAK, A. CHAKRAAVARTI, M. BIBBY: 'A new finite element model for welding heat sources', *Metallurgical Transactions B*, pp. 299-305, 1984.